

1 2 3 4 5 6 7

A

B

C

D

E

A

B

C

D

E

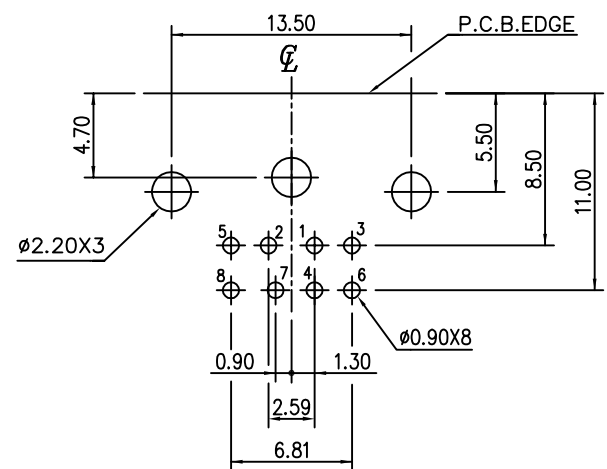
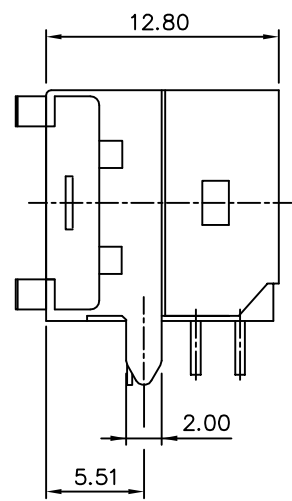
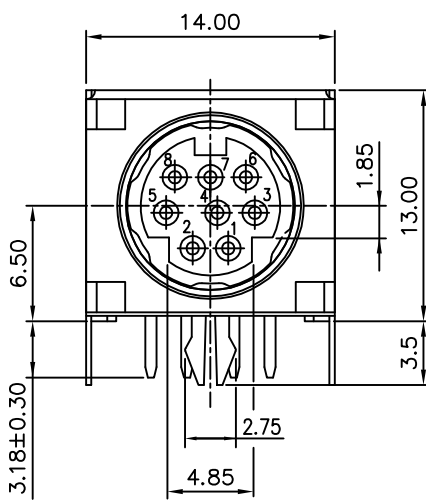

P.C.B. RECOMMEND LAYOUT
(BOTTOM VIEW)

NOTES:

1. MATERIAL
HOUSING : THERMOPLASTIC, GLASS FIBER FILLED
UL 94V-0 RATED.
CONTACT : PHOSPHOR BRONZE
SHIELD : BRASS
GROUNDING: STAINLESS STEEL
2. FINISH
CONTACT : UNDER PLATED 50u"MIN. NICKEL COVER ALL
120u" MIN. TIN IN SOLDERING AREA
SELECTIVE GOLD PLATED IN CONTACT AREA.
SHIELD : (L)BRIGHT TIN , PLATED WITH 120u"THICK.
OVER 50u"THICKNESS Ni.
(S)TIN , PLATED WITH 120u"THICK,
OVER 100u"THICKNESS Cu.
(N)NICKEL , PLATED WITH 120u"THICK,
OVER 100u"THICKNESS Cu.

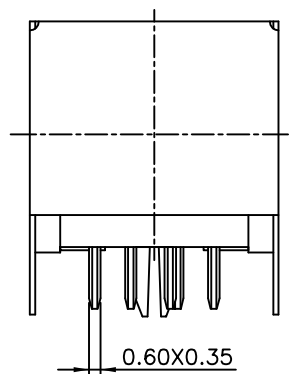
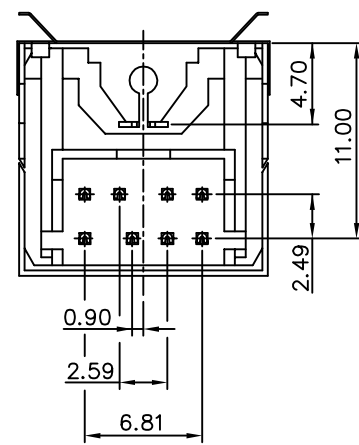

尚益科技有限公司
JMSCONN TECHNOLOGY CO., LED.

PROJ		SCALE : F DO NOT SCALE DWG	MOLD NO 30025-8-03		
APP			MODEL	FILE NO	REV. X1
CHK	CCJ	91.01.16	UNIT MM	SHT 1 OF 1	SIZE A4
DGN	AMY	91.01.16			
DRW	SHIEH	91.01.16			

1 2 3 4 5 6 7