

1 2 3 4 5 6 7

A
B
C
D
E

A
B
C
D
E

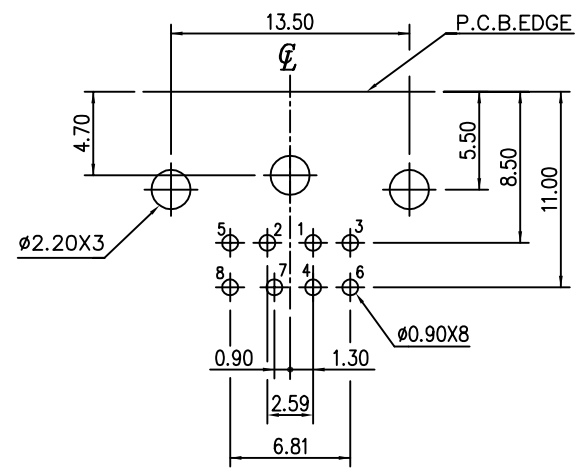
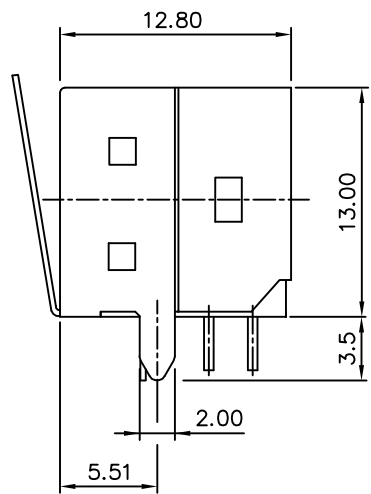
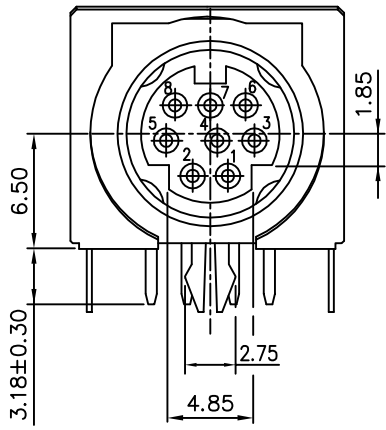

P.C.B. RECOMMEND LAYOUT
(BOTTOM VIEW)

NOTES:

- 1. MATERIAL :
HOUSING : THERMOPLASTIC, GLASS FIBER FILLED
UL 94V-0 RATED.
CONTACT : PHOSPHOR BRONZE
SHIELD : BRASS
GROUNDING: STAINLESS STEEL
- 2. FINISH :
CONTACT : UNDER PLATED 50u"MIN. NICKEL, OVER ALL
120u" MIN. TIN IN SOLDERING AREA,
SELECTIVE GOLD PLATED IN CONTACT AREA.
SHIELD : L: BRIGHT TIN , PLATED WITH 120u"THICK.
OVER 50u"THICKNESS Ni.
S: TIN , PLATED WITH 120u"THICK,
OVER 100u"THICKNESS Cu.
N: NICKEL , PLATED WITH 120u"THICK,
OVER 100u"THICKNESS Cu.

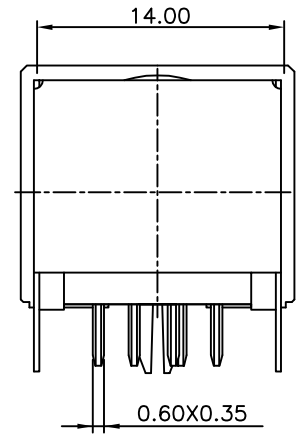
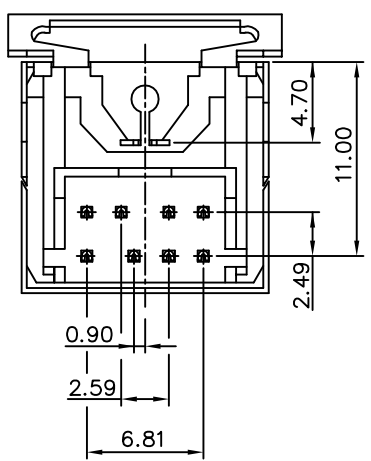

尚益科技有限公司
JMSCONN TECHNOLOGY CO., LED.

PROJ		SCALE : F DO NOT SCALE DWG	MOLD NO 30020-3-08S
APP			MODEL
CHK	CCJ	91.01.16	FILE NO
DGN	AMY	91.01.16	REV. X1
DRW	SHIEH	91.01.16	UNIT MM
			SHT 1 OF 1
			SIZE A4

1 2 3 4 5 6 7