

1 2 3 4 5 6 7

A
B
C
D
E

A
B
C
D
E

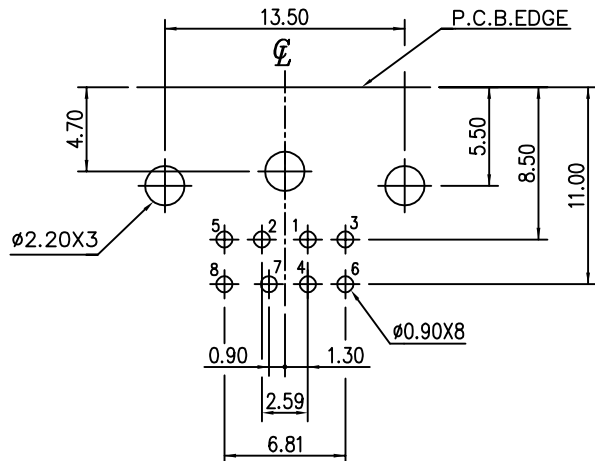
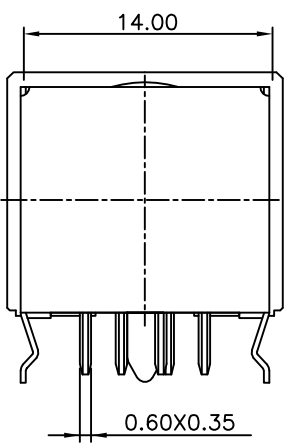
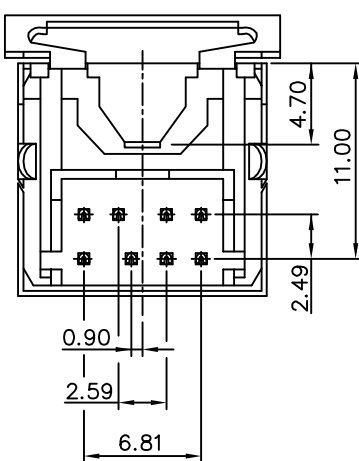
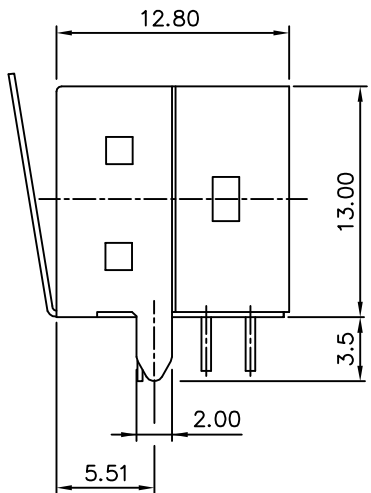
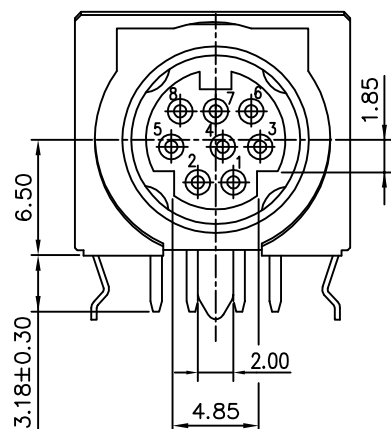

P.C.B. RECOMMEND LAYOUT
(BOTTOM VIEW)

- NOTES:
- MATERIAL :
HOUSING : THERMOPLASTIC, GLASS FIBER FILLED
UL 94V-0 RATED.
CONTACT : PHOSPHOR BRONZE
SHIELD : BRASS
GROUNDING: STAINLESS STEEL
 - FINISH :
CONTACT : UNDER PLATED 50u"MIN. NICKEL, OVER ALL
120u" MIN. TIN IN SOLDERING AREA,
SELECTIVE GOLD PLATED IN CONTACT AREA.
SHIELD : L: BRIGHT TIN , PLATED WITH 120u"THICK.
OVER 50u"THICKNESS Ni.
S: TIN , PLATED WITH 120u"THICK,
OVER 100u"THICKNESS Cu.
N: NICKEL , PLATED WITH 120u"THICK,
OVER 100u"THICKNESS Cu.

尚益科技有限公司
JMSCONN TECHNOLOGY CO., LED.

PROJ		SCALE : F DO NOT SCALE DWG	MOLD NO 30020-8-03KS		
APP			MODEL	FILE NO	REV. X1
CHK	CCJ	91.01.16			
DGN	AMY	91.01.16	UNIT	SHT 1 OF 1	SIZE A4
DRW	SHIEH	91.01.16	MM		

1 2 3 4 5 6 7