

CABLE:UL 2725 USB 2.0 Version  
 CONDUCTOR:(28AWG\*1PAIR)+28AWG\*2C+AL/MYLAR+DRAIN WIRE+BRAID (80?,????)  
 JACKET:PVC , OD:φ4.5±0.1mm  
 COLOR:BLACK

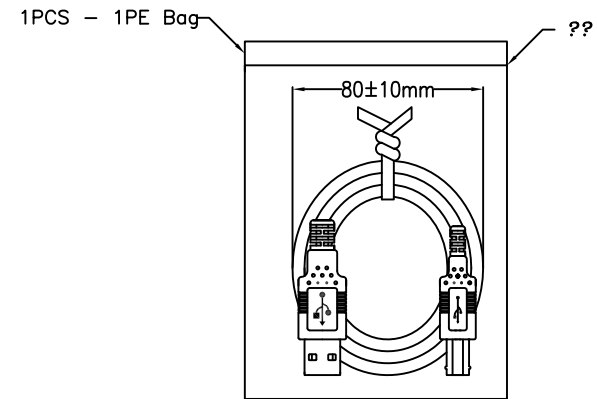

PACKING DETAIL

WIRING DIAGRAM

AWG	USB A-TYPE	USB B-TYPE	NOTE	DESCRIPTION
24AWG	1 (RED)	1	1	USB A-TYPE (MALE) , GOLD FLASH
28AWG	2 (WHITE)	2	2	UL 2725 (28AWG*1P)+28AWG*2C+A+D+B CABLE
28AWG	3 (GREEN)	3	3	USB B-TYPE (MALE) , GOLD FLASH
24AWG	4 (BLACK)	4		
DRAIN	SHELL	SHELL		

尚益科技有限公司 JMSCONN TECHNOLOGY CO., LTD.				
PROJ		SCALE : F DO NOT SCALE DWG	MOLD NO 90010-BA	
APP			MODEL	FILE NO
CHK				REV. X1
DGN			UNIT	SIZE
DRW	HSIEH	2009.01.10	MM	SHT 1 OF 1 A4